

(x4) Ø13

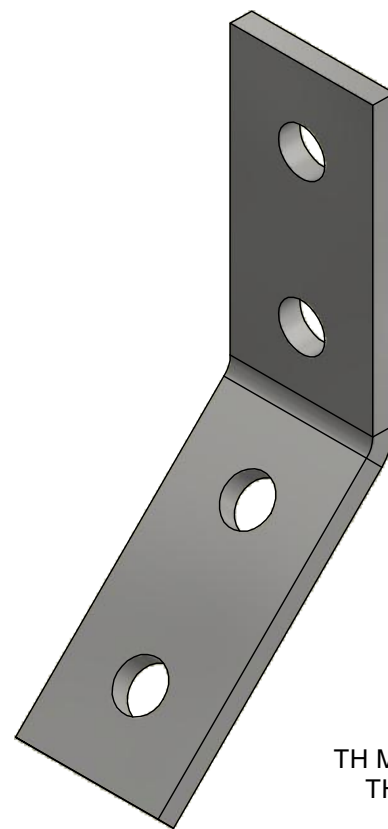

TH M12x25 + RONDELLE Ø12 + ECROU STRUT M12
TH M12x25 + WASHER Ø12 + NUT STRUT M12

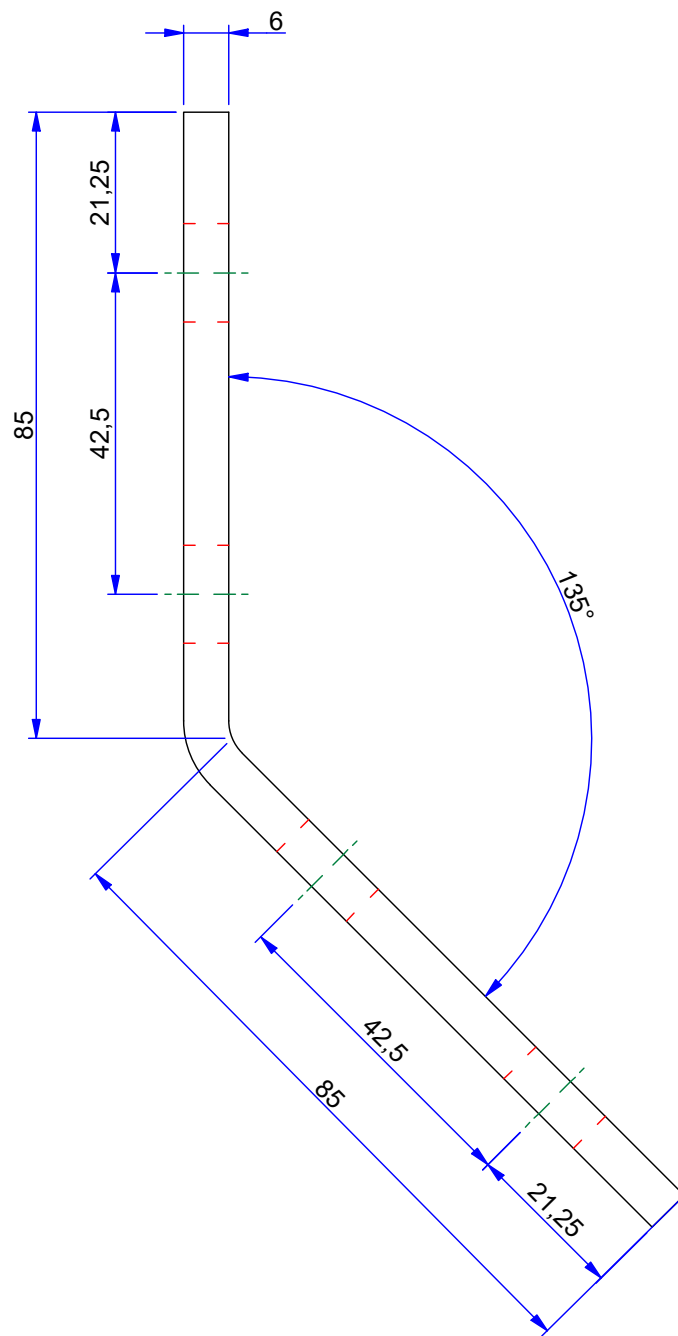
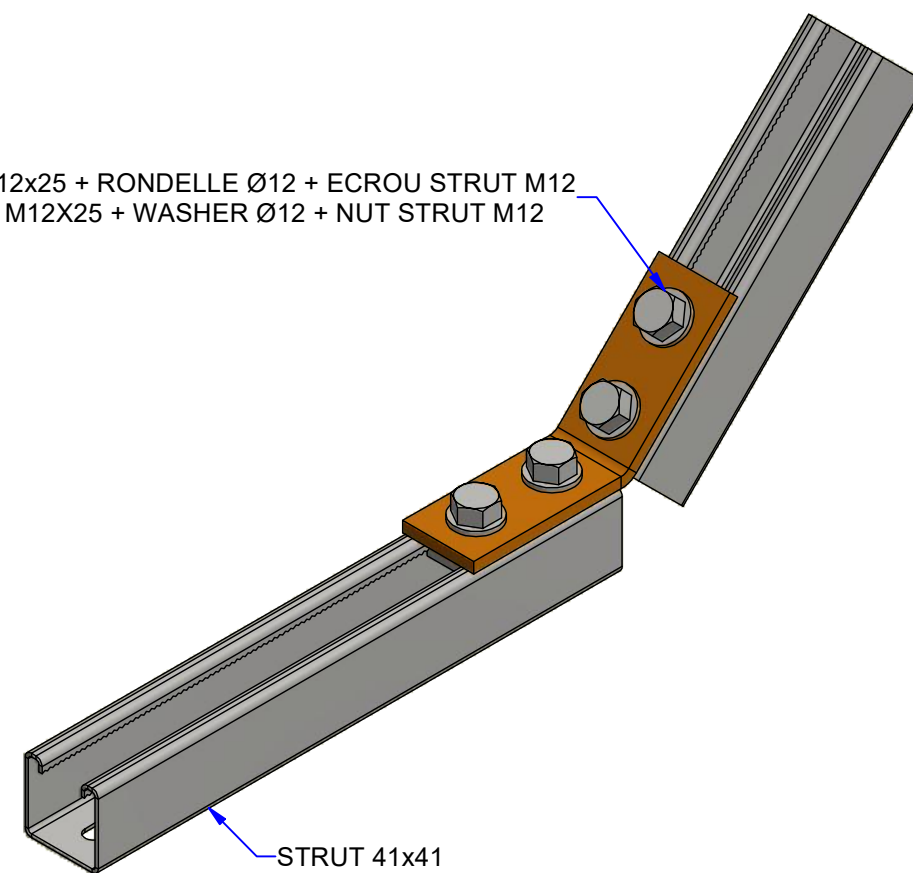

STRUT 41x41

REF.	DESIGNATION	Kg
685203	EQUERRE 135D 4T STRUT 41	0,30

I3 : Tôle d'acier inoxydable suivant NF EN 10088-2 (316L).

SS316L : Stainless steel according to NF EN 10088-2 (316L).

REV.	MODIFICATIONS	DATE	DESSINE PAR	VALIDE PAR
B	Replace perforations Ø12.5 in Ø13 mm	27/08/2020	M.FERRAND	T.LOYER
A	Création du plan / Creation of plan	16/07/2015	M MONPAYS	JF DELANNOY

PS 786 PLAT 41 - 135° 4 TROUS I3
PS 786 FLAT 41 - 135° 4 HOLES SS316L

NIEDAX ASSISTANCE TECHNIQUE
France Tél : +33 (0)1 55 95 92 17

ECHELLE : 1 : 1



CE PLAN EST NOTRE PROPRIETE : IL NE PEUT ETRE NI REPRODUIT NI COMMUNIQUE SANS NOTRE AUTORISATION ECRITE PREALABLE

Révision

A3 PLAN N° .FT02273 PS 786 PLAT 41 - 135° 4 trous I3

B